

# STARPOWER

SEMICONDUCTOR

IGBT

## GD820HTX75P6HB

750V/820A 6 in one-package

### General Description

STARPOWER IGBT Power Module provides ultra low conduction loss as well as short circuit ruggedness. They are designed for the applications such as hybrid and electric vehicle.

### Features

- Low  $V_{CE(sat)}$  Trench IGBT technology
- Low switching losses
- 6 $\mu$ s short circuit capability
- $V_{CE(sat)}$  with positive temperature coefficient
- Maximum junction temperature 175°C
- Low inductance case
- Fast & soft reverse recovery anti-parallel FWD
- Isolated copper pinfin baseplate using DBC technology

### Typical Applications

- Automotive application
- Hybrid and electric vehicle
- Inverter for motor drive

### Equivalent Circuit Schematic

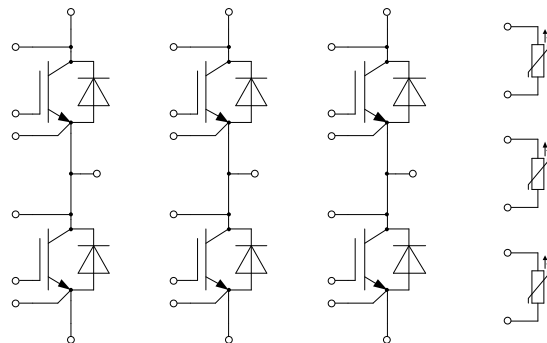

**Absolute Maximum Ratings**  $T_F=25^{\circ}\text{C}$  unless otherwise noted**IGBT**

Symbol	Description	Values	Unit
$V_{CES}$	Collector-Emitter Voltage	750	V
$V_{GES}$	Gate-Emitter Voltage	$\pm 20$	V
$I_{CN}$	Implemented Collector Current	820	A
$I_C$	Collector Current @ $T_F=75^{\circ}\text{C}$	450	A
$I_{CM}$	Pulsed Collector Current $t_p=1\text{ms}$	1640	A
$P_D$	Maximum Power Dissipation @ $T_F=75^{\circ}\text{C}$ $T_j=175^{\circ}\text{C}$	751	W

**Diode**

Symbol	Description	Values	Unit
$V_{RRM}$	Repetitive Peak Reverse Voltage	750	V
$I_{FN}$	Implemented Collector Current	820	A
$I_F$	Diode Continuous Forward Current	450	A
$I_{FM}$	Diode Maximum Forward Current $t_p=1\text{ms}$	1640	A

**Module**

Symbol	Description	Value	Unit
$T_{jmax}$	Maximum Junction Temperature	175	$^{\circ}\text{C}$
$T_{jop}$	Operating Junction Temperature continuous For 10s within a period of 30s, occurrence maximum 3000 times over lifetime	-40 to +150 +150 to +175	$^{\circ}\text{C}$
$T_{STG}$	Storage Temperature Range	-40 to +125	$^{\circ}\text{C}$
$V_{ISO}$	Isolation Voltage RMS, $f=50\text{Hz}$ , $t=1\text{min}$	2500	V

**IGBT Characteristics**  $T_F=25^{\circ}\text{C}$  unless otherwise noted

Symbol	Parameter	Test Conditions	Min.	Typ.	Max.	Unit	
$V_{CE(sat)}$	Collector to Emitter Saturation Voltage	$I_C=450\text{A}, V_{GE}=15\text{V}, T_j=25^{\circ}\text{C}$		1.25	1.50	V	
		$I_C=450\text{A}, V_{GE}=15\text{V}, T_j=150^{\circ}\text{C}$		1.35			
		$I_C=450\text{A}, V_{GE}=15\text{V}, T_j=175^{\circ}\text{C}$		1.40			
		$I_C=820\text{A}, V_{GE}=15\text{V}, T_j=25^{\circ}\text{C}$		1.55			
		$I_C=820\text{A}, V_{GE}=15\text{V}, T_j=175^{\circ}\text{C}$		1.90			
$V_{GE(th)}$	Gate-Emitter Threshold Voltage	$I_C=9.60\text{mA}, V_{CE}=V_{GE}, T_j=25^{\circ}\text{C}$	5.0	5.7	7.0	V	
		$I_C=9.60\text{mA}, V_{CE}=V_{GE}, T_j=175^{\circ}\text{C}$		3.5			
$I_{CES}$	Collector Cut-Off Current	$V_{CE}=V_{CES}, V_{GE}=0\text{V}, T_j=25^{\circ}\text{C}$			1.0	mA	
$I_{GES}$	Gate-Emitter Leakage Current	$V_{GE}=V_{GES}, V_{CE}=0\text{V}, T_j=25^{\circ}\text{C}$			400	nA	
$R_{Gint}$	Internal Gate Resistance			0.7		$\Omega$	
$C_{ies}$	Input Capacitance			42.1		nF	
$C_{oes}$	Output Capacitance	$V_{CE}=50\text{V}, f=100\text{kHz}, V_{GE}=0\text{V}$		1.80		nF	
$C_{res}$	Reverse Transfer Capacitance			1.18		nF	
$Q_G$	Gate Charge	$V_{CE}=400\text{V}, I_C=450\text{A}, V_{GE}=-8\dots+15\text{V}$		3.01		$\mu\text{C}$	
$t_{d(on)}$	Turn-On Delay Time	$V_{CC}=400\text{V}, I_C=450\text{A}, R_G=2.4\Omega, L_S=24\text{nH}, V_{GE}=-8\text{V}/+15\text{V}, T_j=25^{\circ}\text{C}$		126		ns	
$t_r$	Rise Time			62		ns	
$t_{d(off)}$	Turn-Off Delay Time			639		ns	
$t_f$	Fall Time			149		ns	
$E_{on}$	Turn-On Switching Loss			17.3		mJ	
$E_{off}$	Turn-Off Switching Loss			25.4		mJ	
$t_{d(on)}$	Turn-On Delay Time		$V_{CC}=400\text{V}, I_C=450\text{A}, R_G=2.4\Omega, L_S=24\text{nH}, V_{GE}=-8\text{V}/+15\text{V}, T_j=150^{\circ}\text{C}$		136		ns
$t_r$	Rise Time				68		ns
$t_{d(off)}$	Turn-Off Delay Time				715		ns
$t_f$	Fall Time				221		ns
$E_{on}$	Turn-On Switching Loss			22.5		mJ	
$E_{off}$	Turn-Off Switching Loss			31.0		mJ	
$t_{d(on)}$	Turn-On Delay Time	$V_{CC}=400\text{V}, I_C=450\text{A}, R_G=2.4\Omega, L_S=24\text{nH}, V_{GE}=-8\text{V}/+15\text{V}, T_j=175^{\circ}\text{C}$			138		ns
$t_r$	Rise Time				68		ns
$t_{d(off)}$	Turn-Off Delay Time				739		ns
$t_f$	Fall Time				227		ns
$E_{on}$	Turn-On Switching Loss			24.8		mJ	
$E_{off}$	Turn-Off Switching Loss			32.6		mJ	
$I_{SC}$	SC Data		$t_p \leq 6\mu\text{s}, V_{GE}=15\text{V}$		5100		A

		$T_j=25^{\circ}\text{C}, V_{CC}=400\text{V},$ $V_{CEM}\leq 750\text{V}$				
		$t_p\leq 3\mu\text{s}, V_{GE}=15\text{V},$ $T_j=175^{\circ}\text{C}, V_{CC}=400\text{V},$ $V_{CEM}\leq 750\text{V}$		3800		

### Diode Characteristics $T_F=25^{\circ}\text{C}$ unless otherwise noted

Symbol	Parameter	Test Conditions	Min.	Typ.	Max.	Unit
$V_F$	Diode Forward Voltage	$I_F=450\text{A}, V_{GE}=0\text{V}, T_j=25^{\circ}\text{C}$		1.40	1.65	V
		$I_F=450\text{A}, V_{GE}=0\text{V}, T_j=150^{\circ}\text{C}$		1.35		
		$I_F=450\text{A}, V_{GE}=0\text{V}, T_j=175^{\circ}\text{C}$		1.30		
		$I_F=820\text{A}, V_{GE}=0\text{V}, T_j=25^{\circ}\text{C}$		1.70		
		$I_F=820\text{A}, V_{GE}=0\text{V}, T_j=175^{\circ}\text{C}$		1.65		
$Q_r$	Recovered Charge			16.0		$\mu\text{C}$
$I_{RM}$	Peak Reverse Recovery Current	$V_R=400\text{V}, I_F=450\text{A},$ $-di/dt=7070\text{A}/\mu\text{s}, V_{GE}=-8\text{V},$ $L_S=24\text{nH}, T_j=25^{\circ}\text{C}$		254		A
$E_{rec}$	Reverse Recovery Energy			5.03		mJ
$Q_r$	Recovered Charge			36.0		$\mu\text{C}$
$I_{RM}$	Peak Reverse Recovery Current	$V_R=400\text{V}, I_F=450\text{A},$ $-di/dt=6150\text{A}/\mu\text{s}, V_{GE}=-8\text{V},$ $L_S=24\text{nH}, T_j=150^{\circ}\text{C}$		320		A
$E_{rec}$	Reverse Recovery Energy			9.49		mJ
$Q_r$	Recovered Charge			40.5		$\mu\text{C}$
$I_{RM}$	Peak Reverse Recovery Current	$V_R=400\text{V}, I_F=450\text{A},$ $-di/dt=6010\text{A}/\mu\text{s}, V_{GE}=-8\text{V},$ $L_S=24\text{nH}, T_j=175^{\circ}\text{C}$		338		A
$E_{rec}$	Reverse Recovery Energy			10.5		mJ

### NTC Characteristics $T_F=25^{\circ}\text{C}$ unless otherwise noted

Symbol	Parameter	Test Conditions	Min.	Typ.	Max.	Unit
$R_{25}$	Rated Resistance			5.0		$\text{k}\Omega$
$\Delta R/R$	Deviation of $R_{100}$	$T_C=100^{\circ}\text{C}, R_{100}=493.3\Omega$	-5		5	%
$P_{25}$	Power Dissipation				20.0	mW
$B_{25/50}$	B-value	$R_2=R_{25}\exp[B_{25/50}(1/T_2-1/(298.15\text{K}))]$		3375		K
$B_{25/80}$	B-value	$R_2=R_{25}\exp[B_{25/80}(1/T_2-1/(298.15\text{K}))]$		3411		K
$B_{25/100}$	B-value	$R_2=R_{25}\exp[B_{25/100}(1/T_2-1/(298.15\text{K}))]$		3433		K

**Module Characteristics**  $T_F=25^{\circ}\text{C}$  unless otherwise noted

Symbol	Parameter	Min.	Typ.	Max.	Unit
$L_{CE}$	Stray Inductance		8		nH
$R_{CC'+EE'}$	Module Lead Resistance, Terminal to Chip		0.75		m $\Omega$
$\Delta p$	$\Delta V/\Delta t=10.0\text{dm}^3/\text{min}, T_F=75^{\circ}\text{C}$		64		mbar
p	Maximum Pressure In Cooling Circuit $T_{\text{baseplate}} < 40^{\circ}\text{C}$ $T_{\text{baseplate}} > 40^{\circ}\text{C}$ (relative pressure)			2.5 2.0	bar
$R_{thJF}$	Junction-to-Cooling Fluid (per IGBT) Junction-to-Cooling Fluid (per Diode) $\Delta V/\Delta t=10.0\text{dm}^3/\text{min}, T_F=75^{\circ}\text{C}$		0.116 0.175	0.133 0.200	K/W
M	Terminal Connection Torque, Screw M5 Mounting Torque, Screw M4	3.6 1.8		4.4 2.2	N.m
G	Weight of Module		750		g

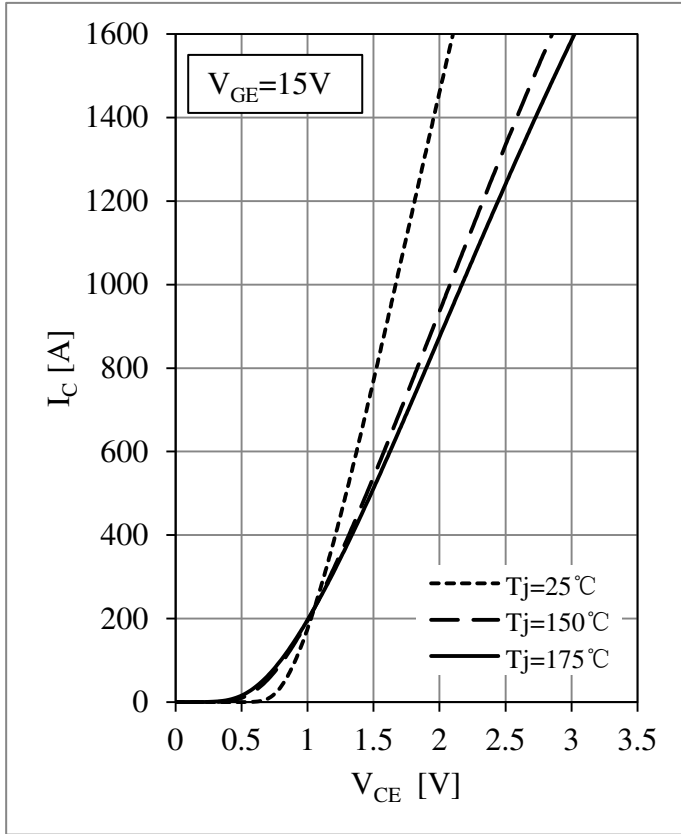

Fig 1. IGBT Output Characteristics

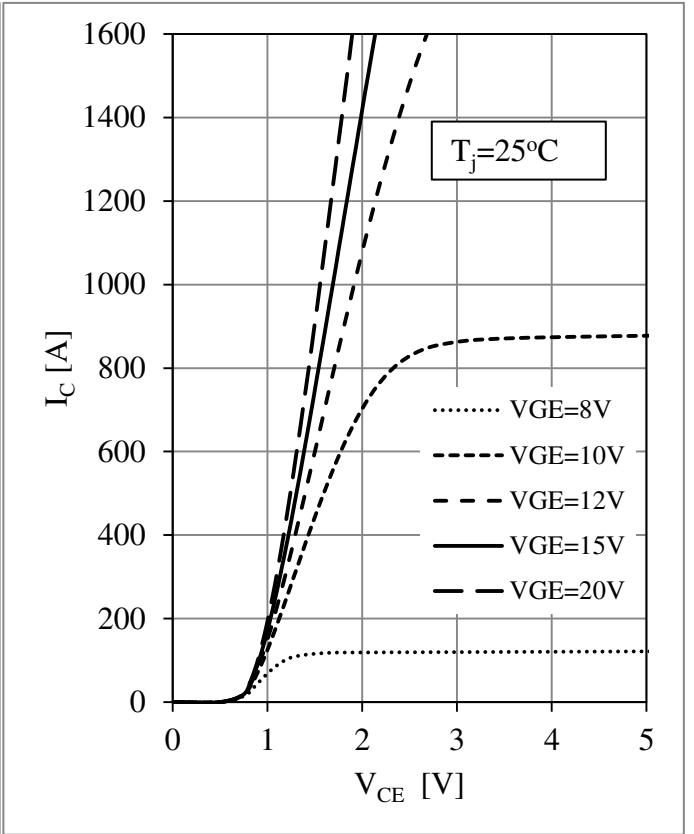

Fig 2. IGBT Output Characteristics

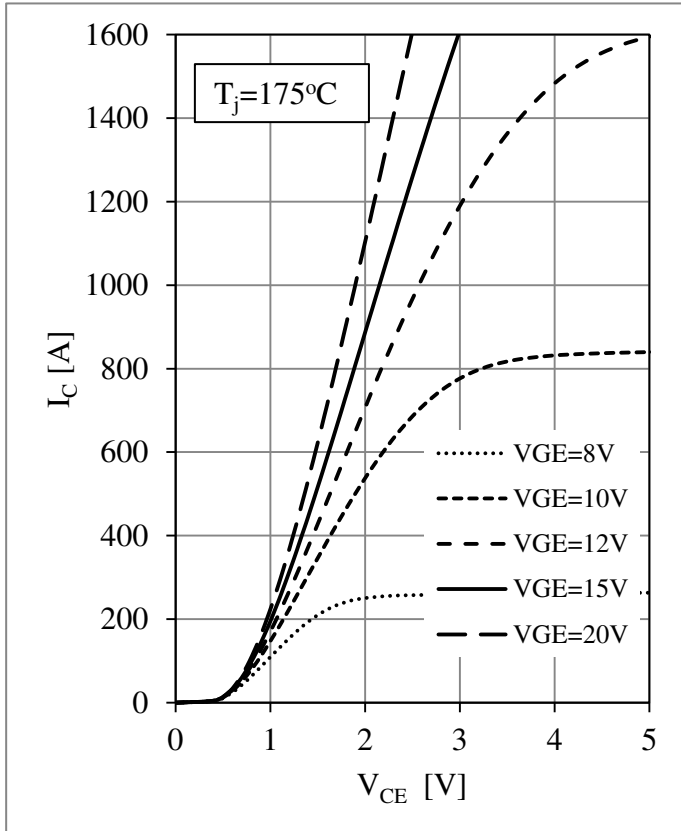

Fig 3. IGBT Output Characteristics

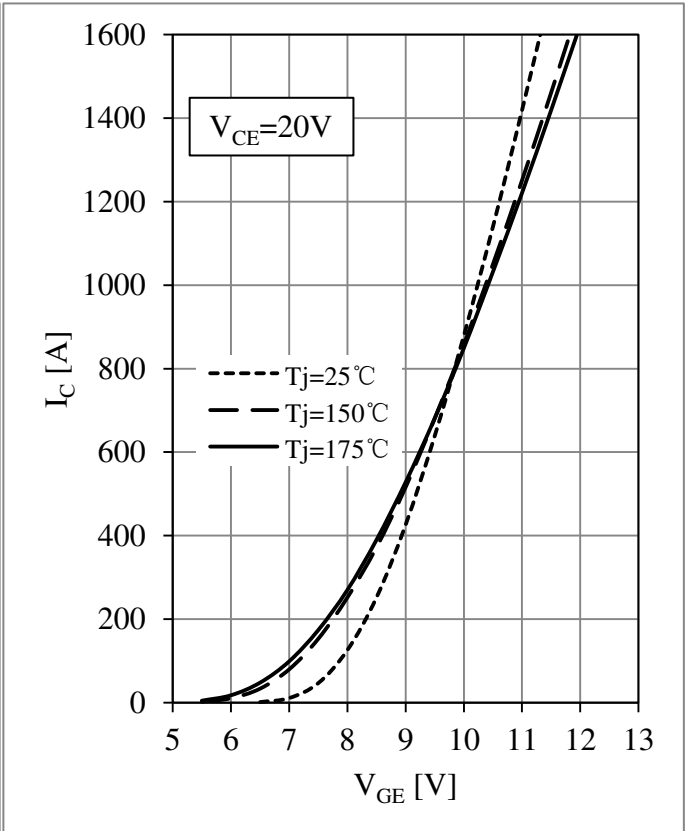

Fig 4. IGBT Transfer Characteristics

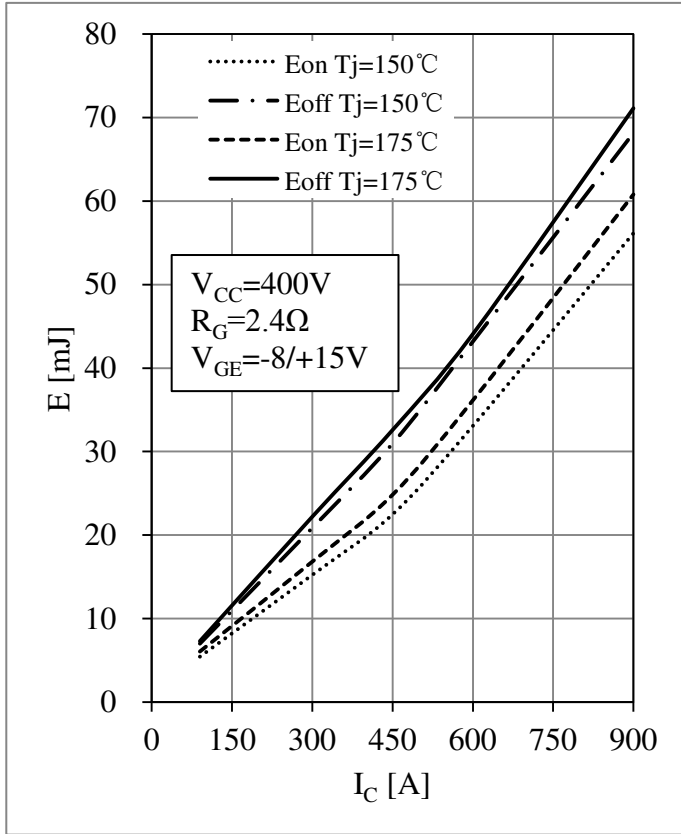

Fig 5. IGBT Switching Loss vs.  $I_c$

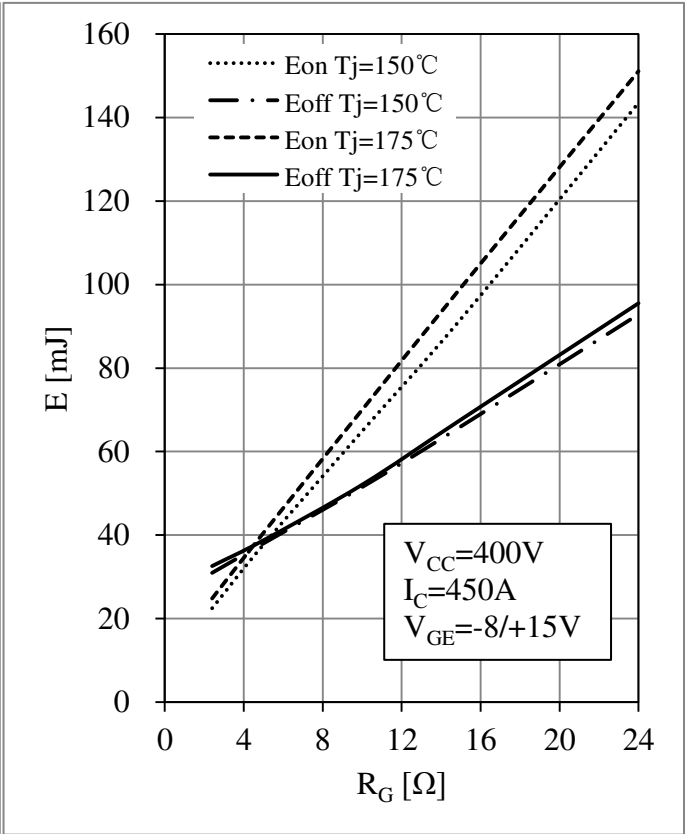

Fig 6. IGBT Switching Loss vs.  $R_G$

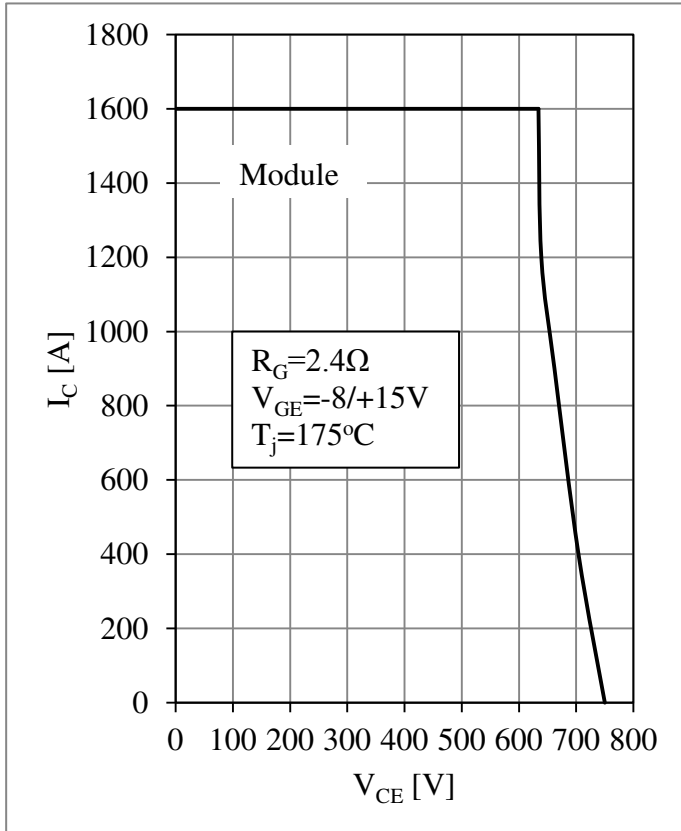

Fig 7. RBSOA

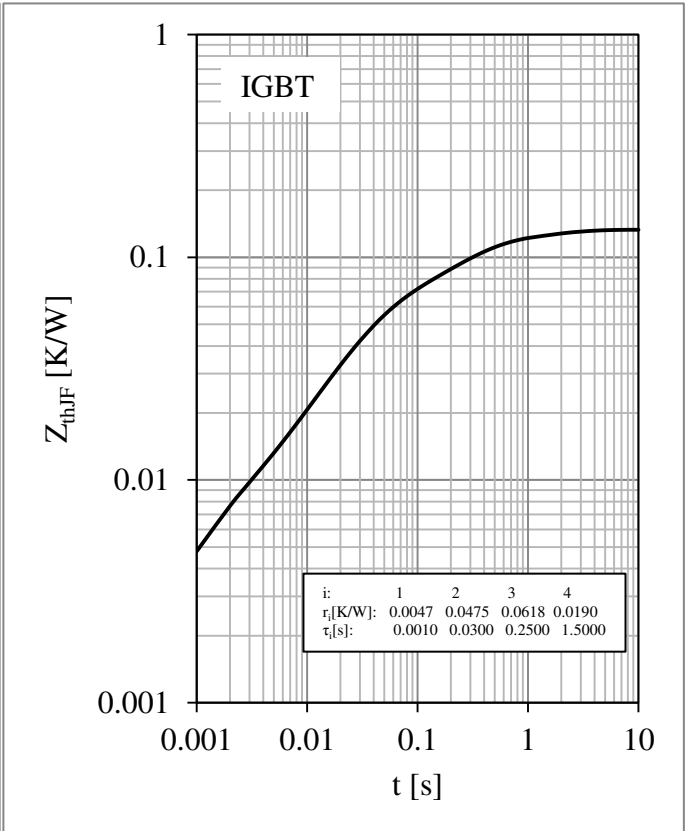

Fig 8. IGBT Transient Thermal Impedance

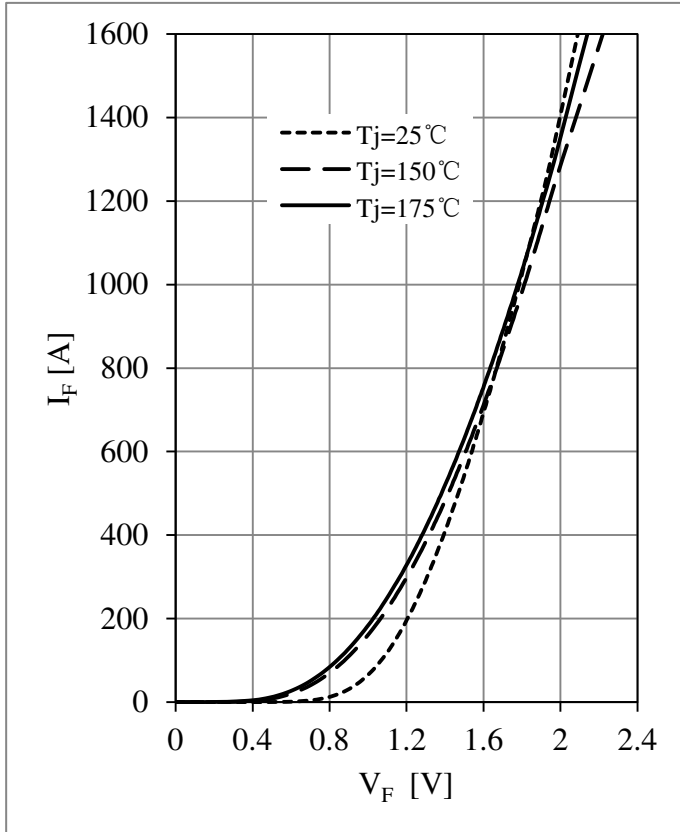

Fig 9. Diode Forward Characteristics

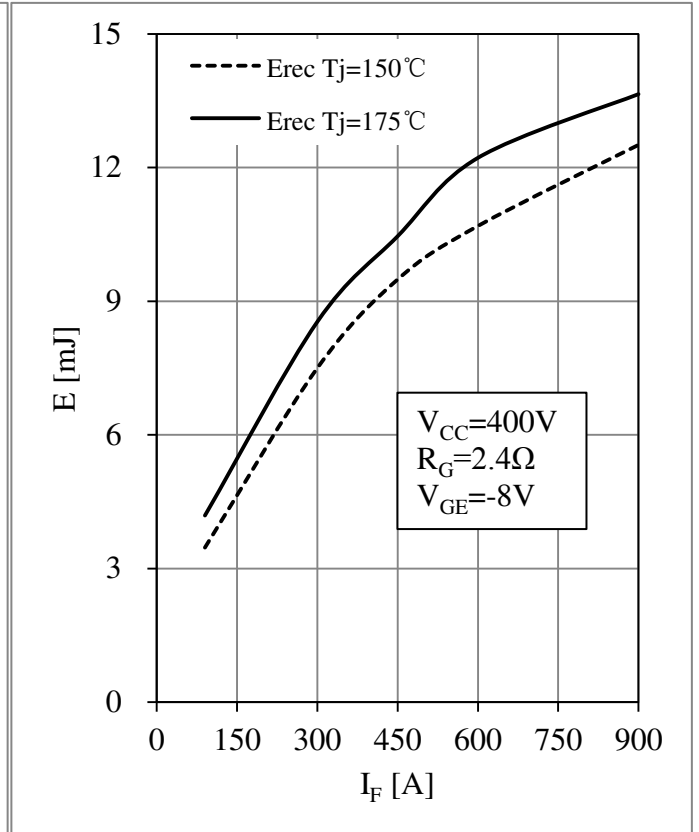

Fig 10. Diode Switching Loss vs.  $I_F$

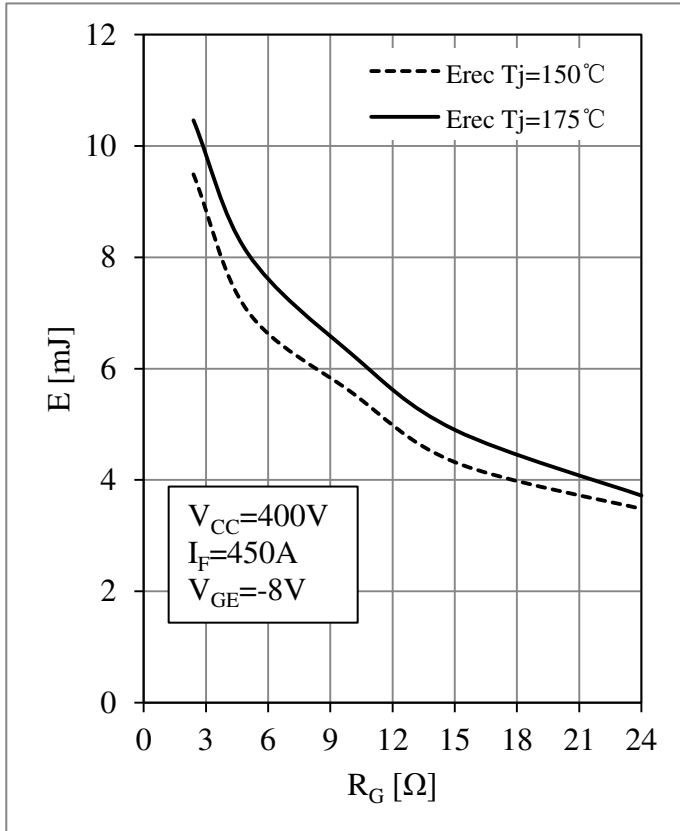

Fig 11. Diode Switching Loss vs.  $R_G$

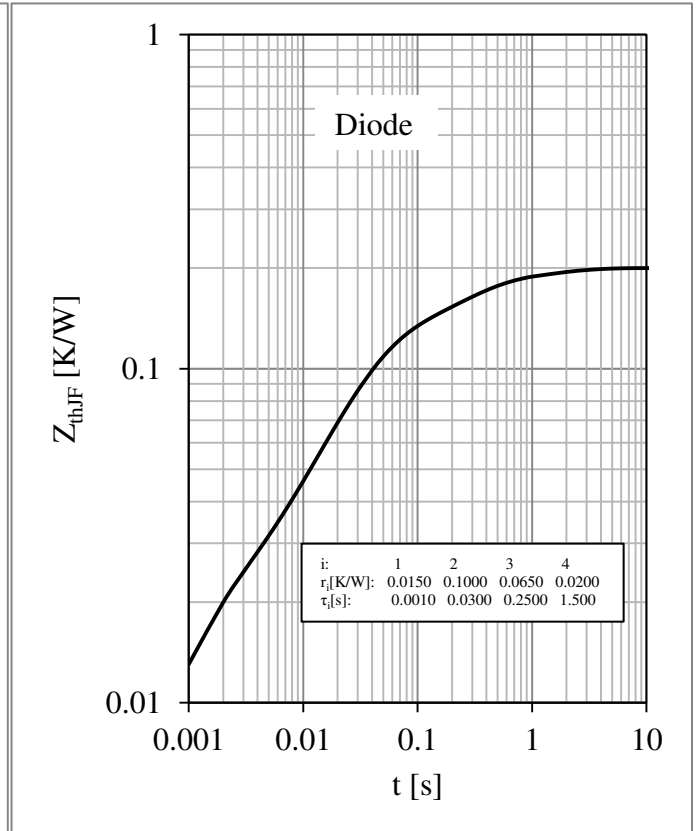

Fig 12. Diode Transient Thermal Impedance



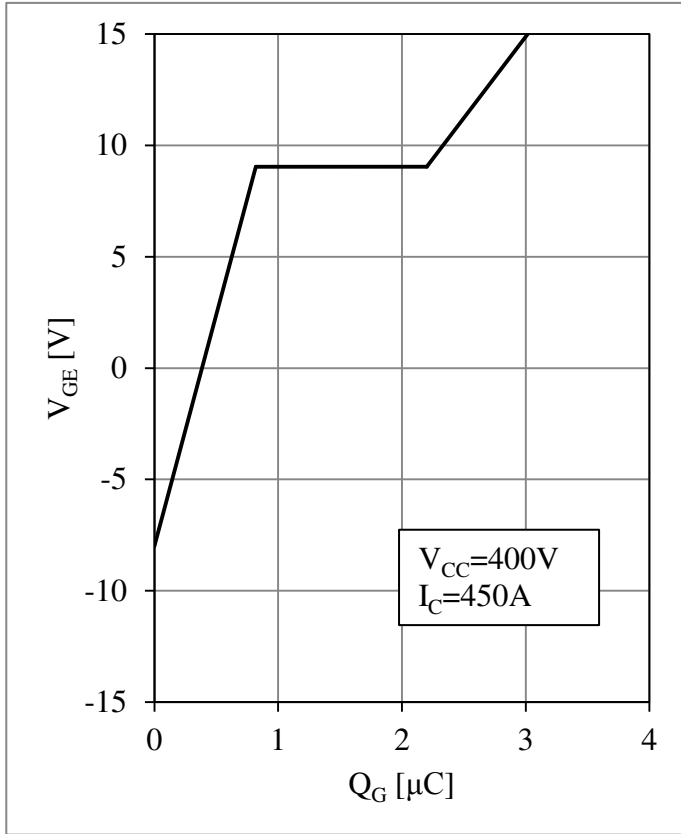

Fig 13. IGBT Gate Charge Characteristic

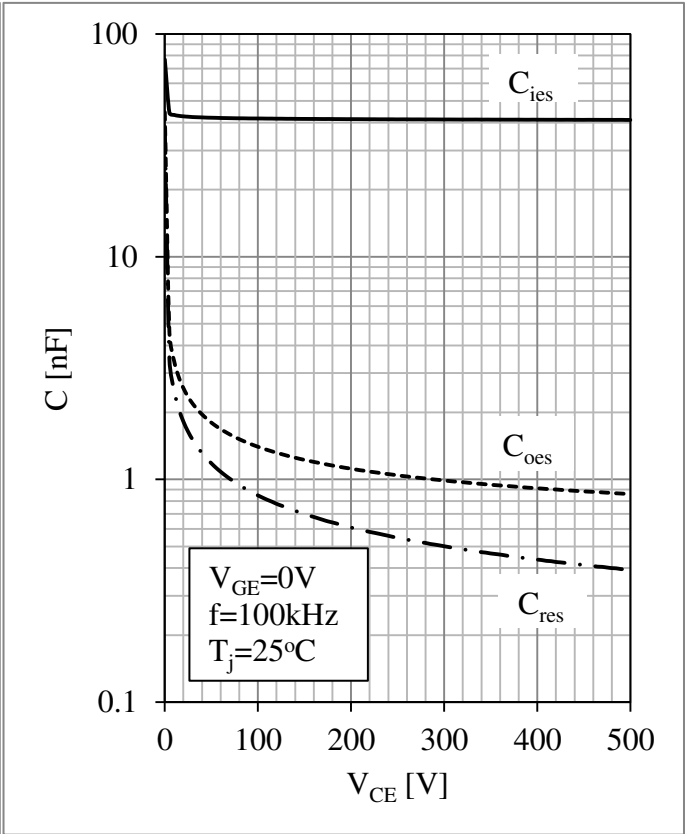

Fig 14. IGBT Capacity Characteristic

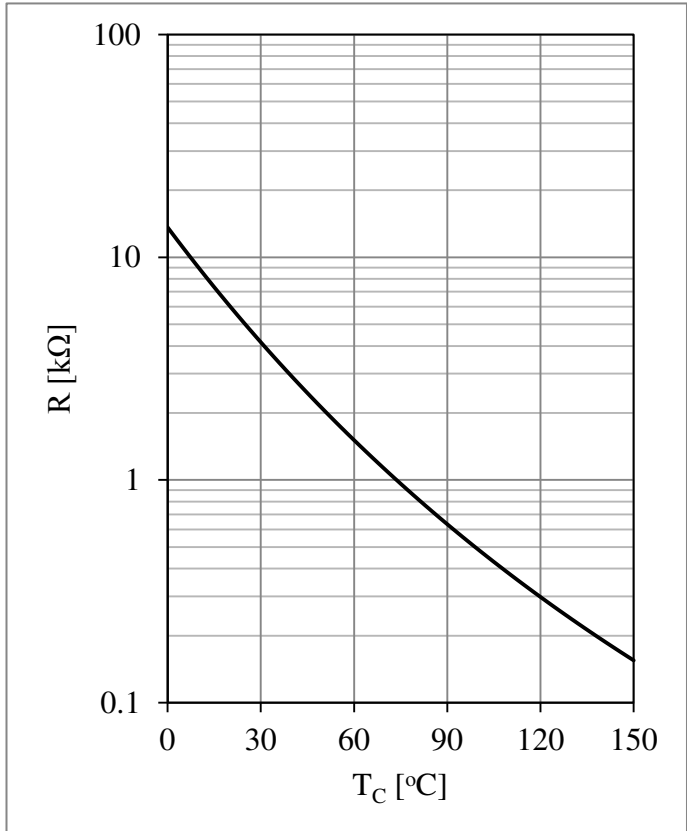

Fig 15. NTC Temperature Characteristic

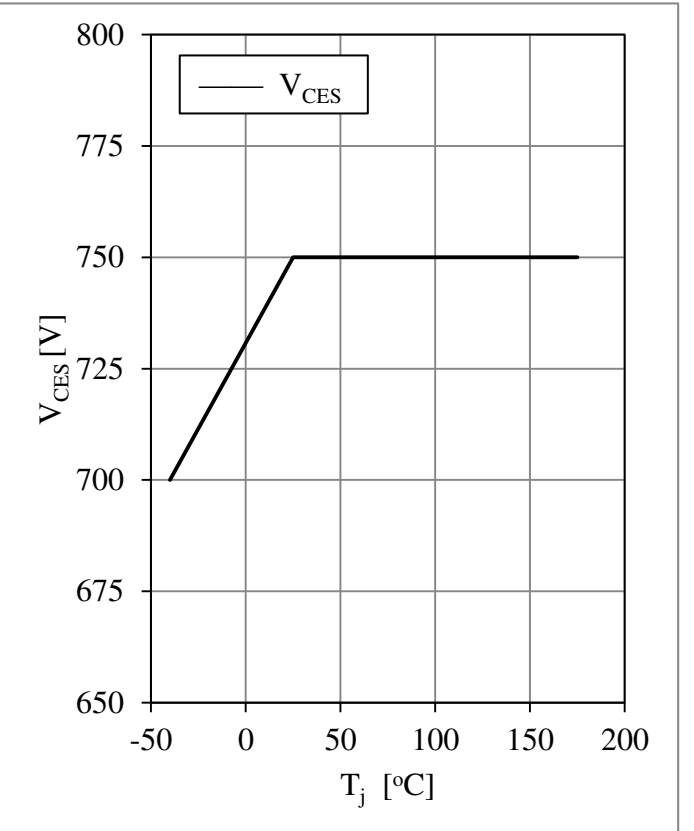
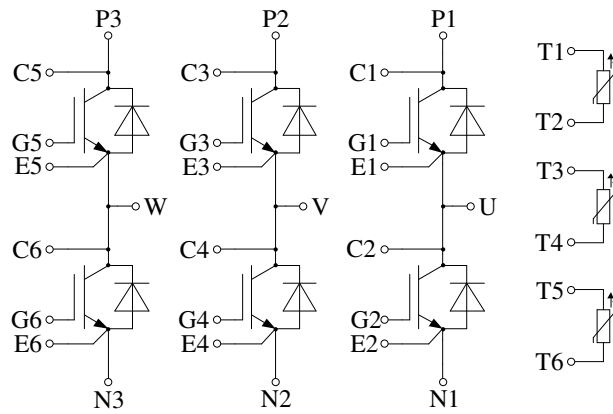

Fig 16. Maximum Allowed Collector-Emitter Voltage

Circuit Schematic



Package Dimensions

Dimensions in Millimeters

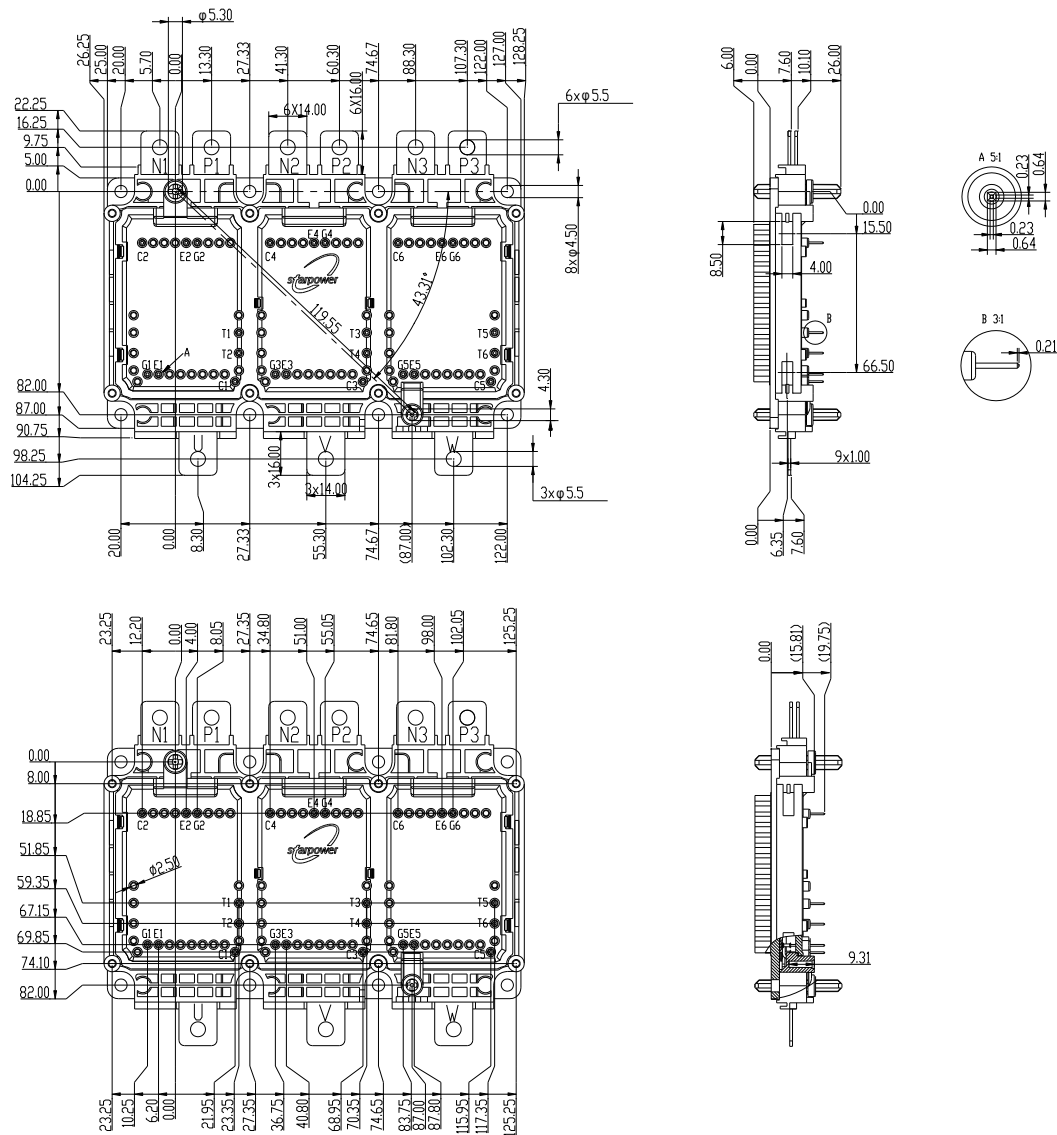

## Terms and Conditions of Usage

The data contained in this product datasheet is exclusively intended for technically trained staff. you and your technical departments will have to evaluate the suitability of the product for the intended application and the completeness of the product data with respect to such application.

This product data sheet is describing the characteristics of this product for which a warranty is granted. Any such warranty is granted exclusively pursuant the terms and conditions of the supply agreement. There will be no guarantee of any kind for the product and its characteristics.

Should you require product information in excess of the data given in this product data sheet or which concerns the specific application of our product, please contact the sales office, which is responsible for you (see [www.powersemi.cc](http://www.powersemi.cc)), For those that are specifically interested we may provide application notes.

Due to technical requirements our product may contain dangerous substances. For information on the types in question please contact the sales office, which is responsible for you.

Should you intend to use the Product in aviation applications, in health or live endangering or life support applications, please notify.

If and to the extent necessary, please forward equivalent notices to your customers.  
Changes of this product data sheet are reserved.