

Toleranz von $\pm 15\%$ auf alle Anziehdrehmomente, sofern nicht anders angegeben.

Tightening torques are given with a tolerance of $\pm 15\%$ unless otherwise stated.

Les couples de serrages sont donnés avec une tolérance de $\pm 15\%$ sauf autre indication.

1

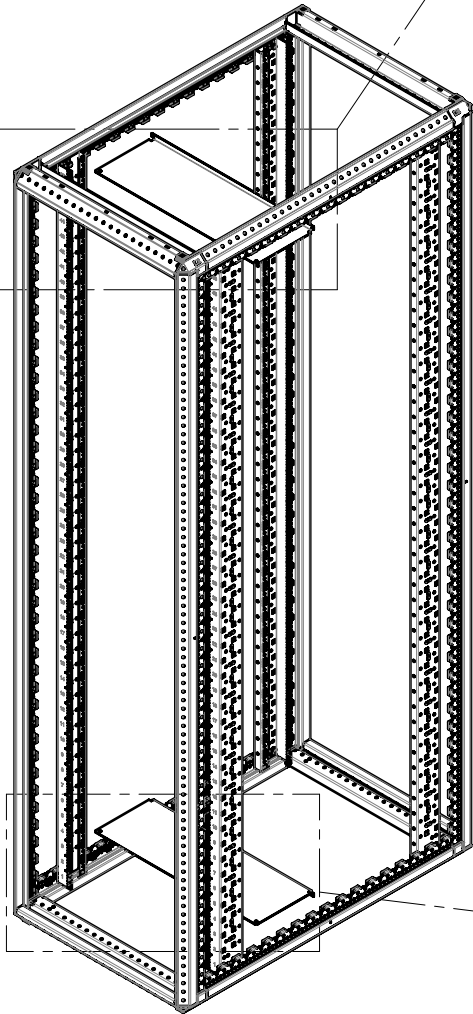
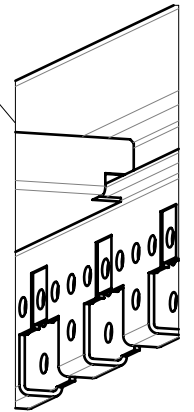
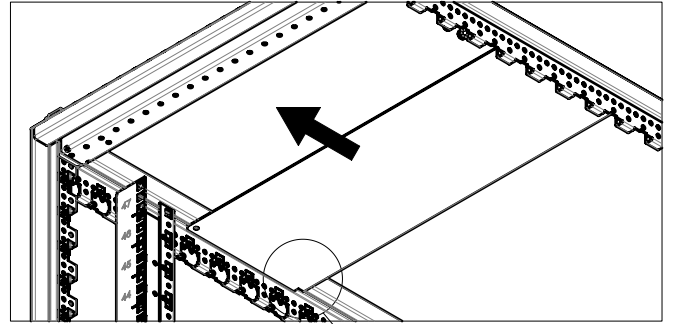
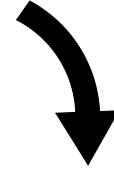
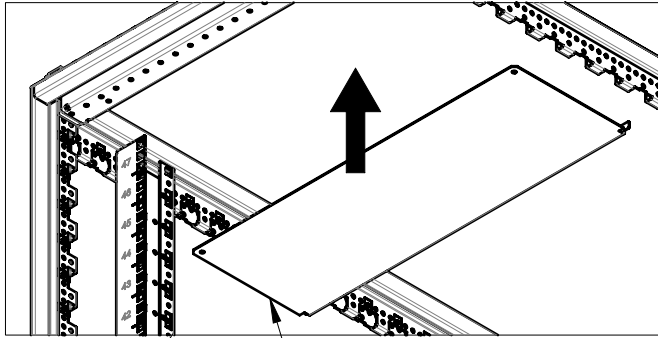

1

1

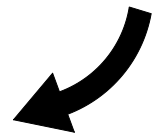
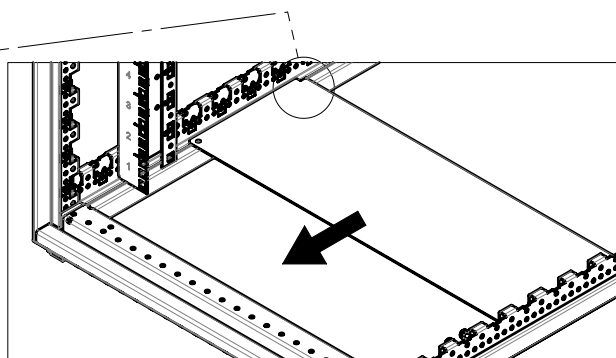
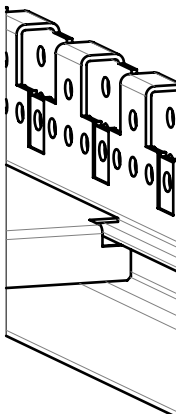
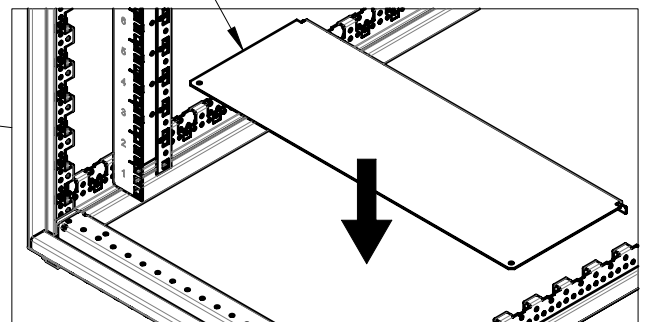

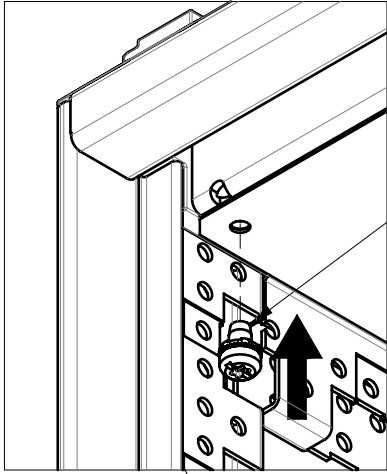

2(4x)
5Nm

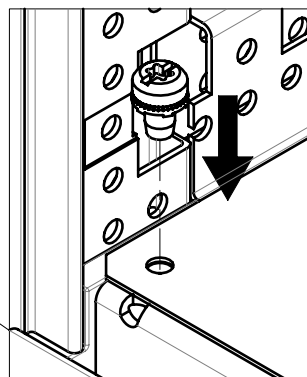
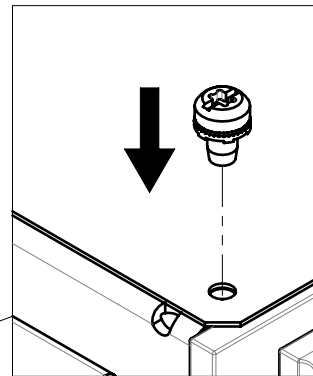
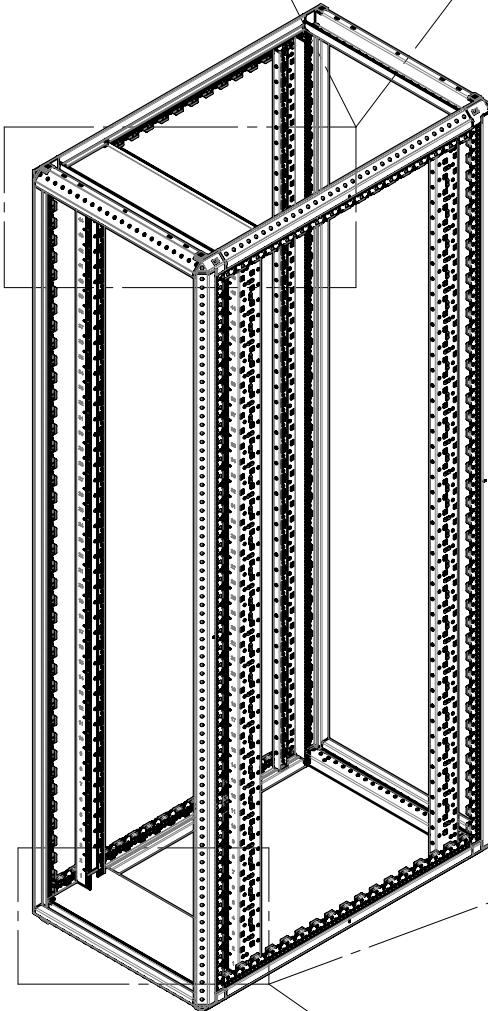
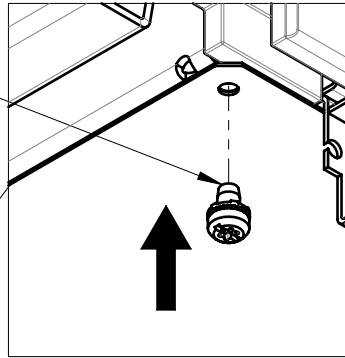

3a

Für Schrankhöhe
2000 und 2450

For cabinet
2000 and 2450 height

Pour baie hauteur
2000 et 2450

2(4x)
5Nm

4(2x)

3(2x)

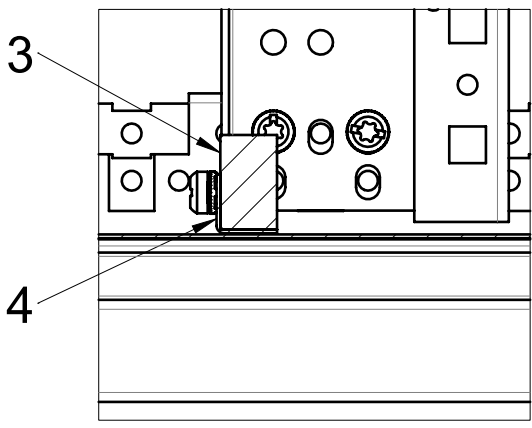
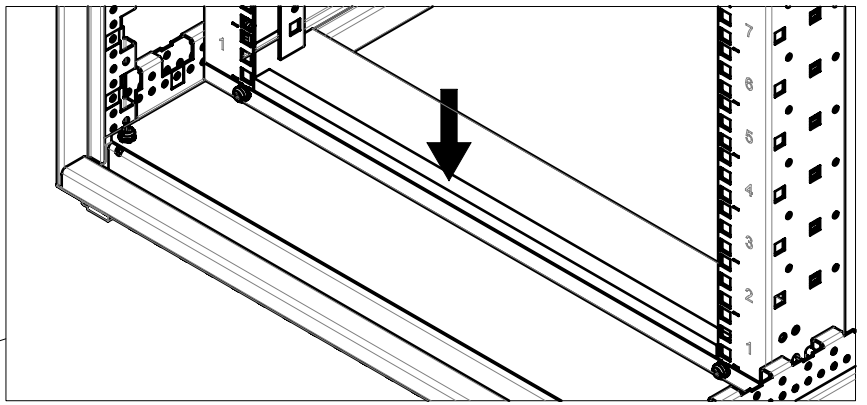
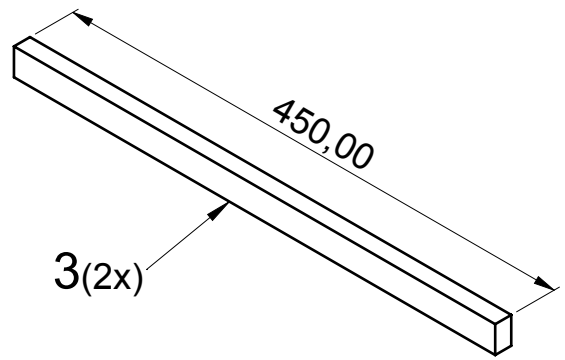
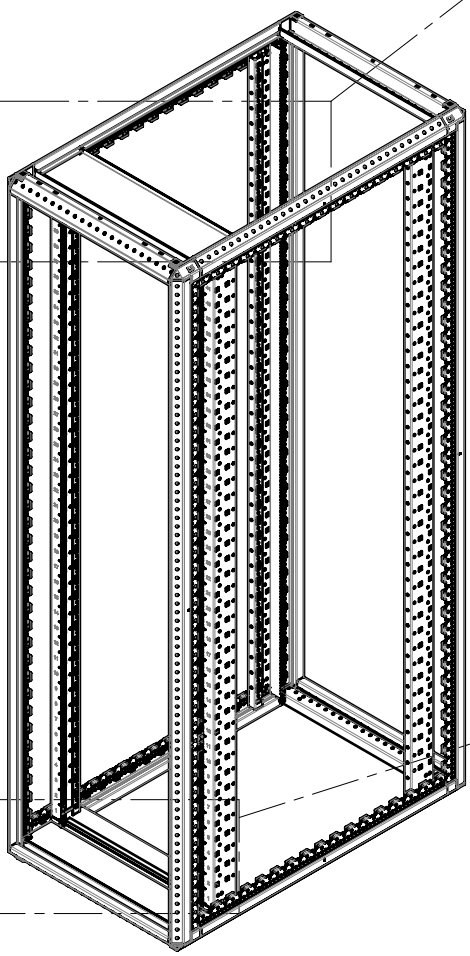
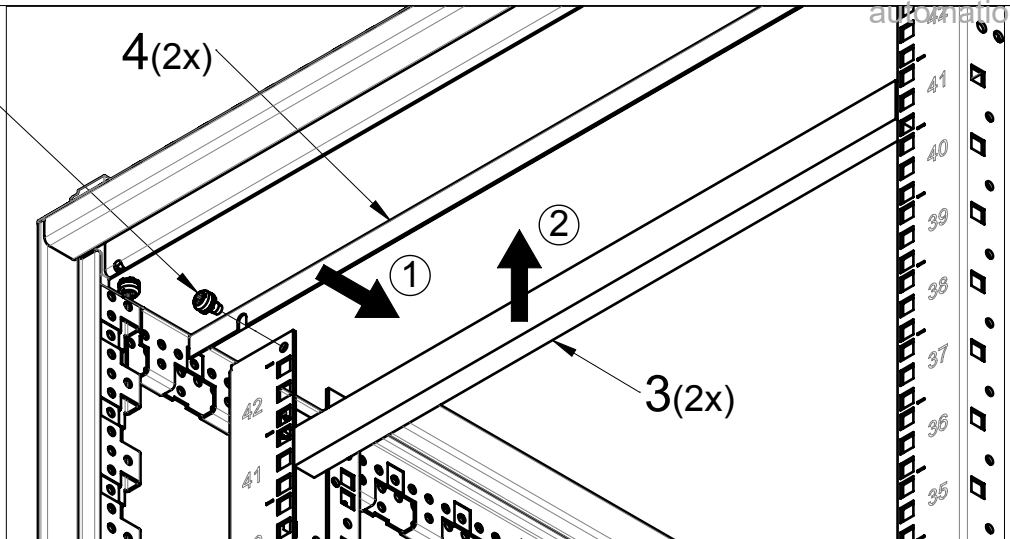

3b

Für Schrankhöhe 2200

For cabinet 2200 height

Pour baie hauteur 2200

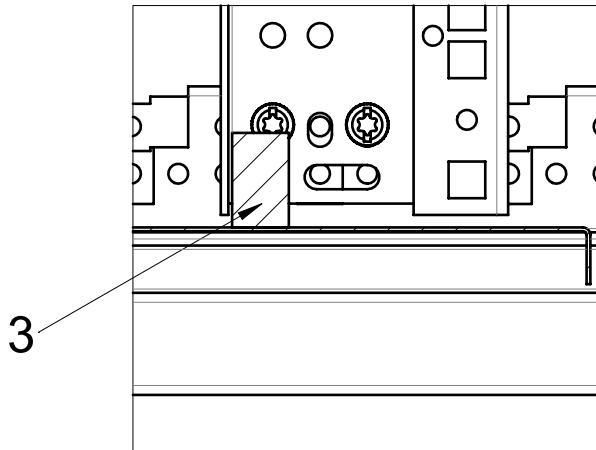
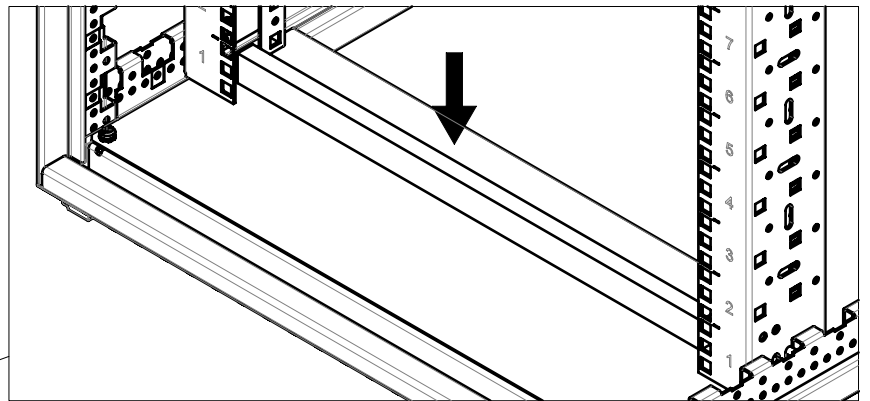
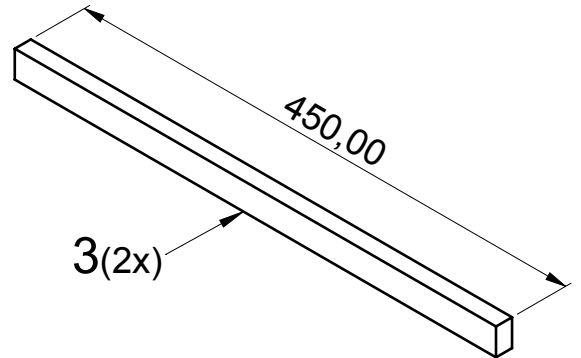
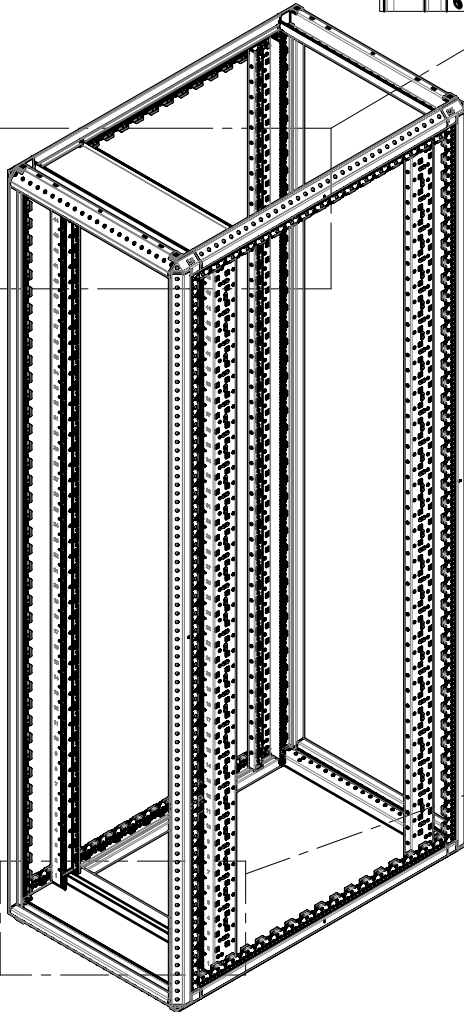
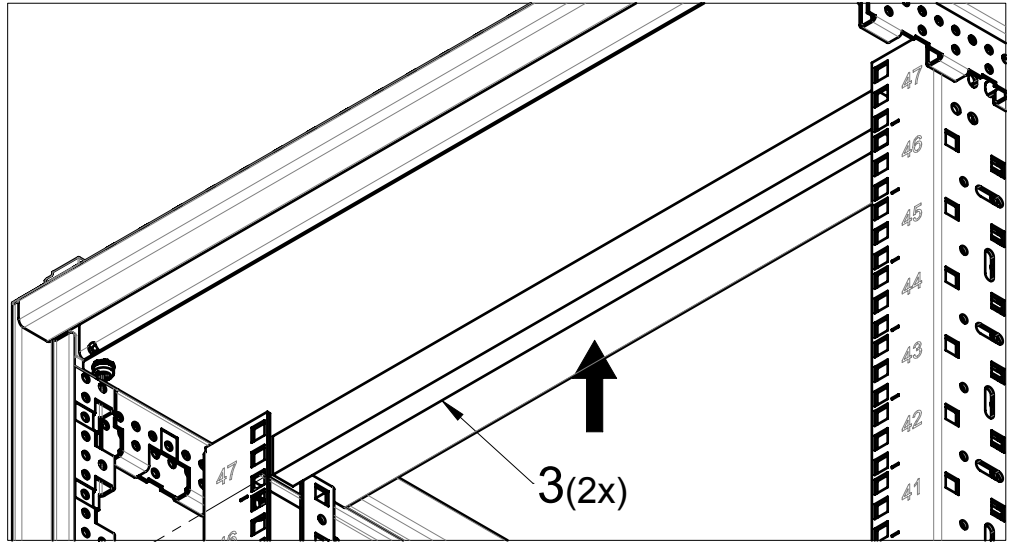

4

